

SCHNITT R

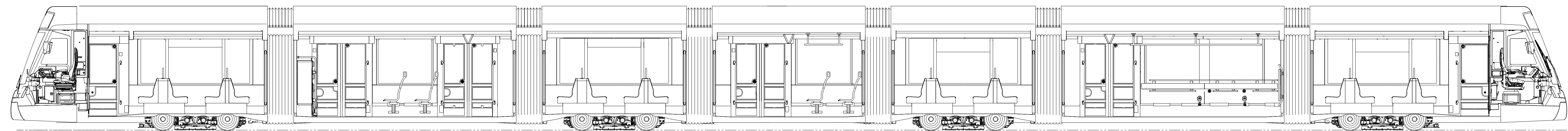

SCHNITT S

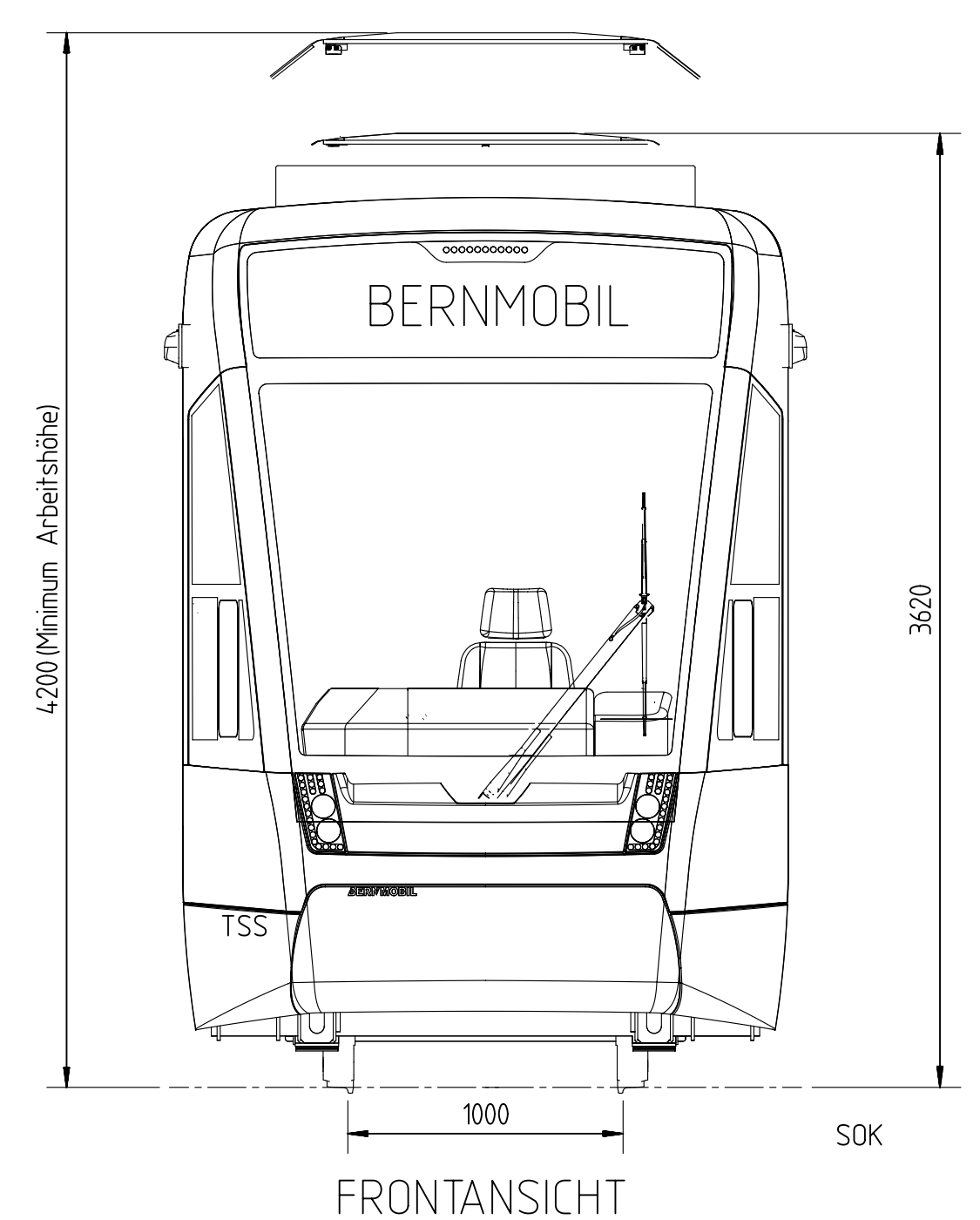
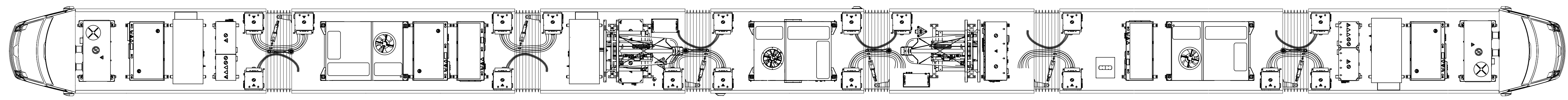

FRONTANSICHT

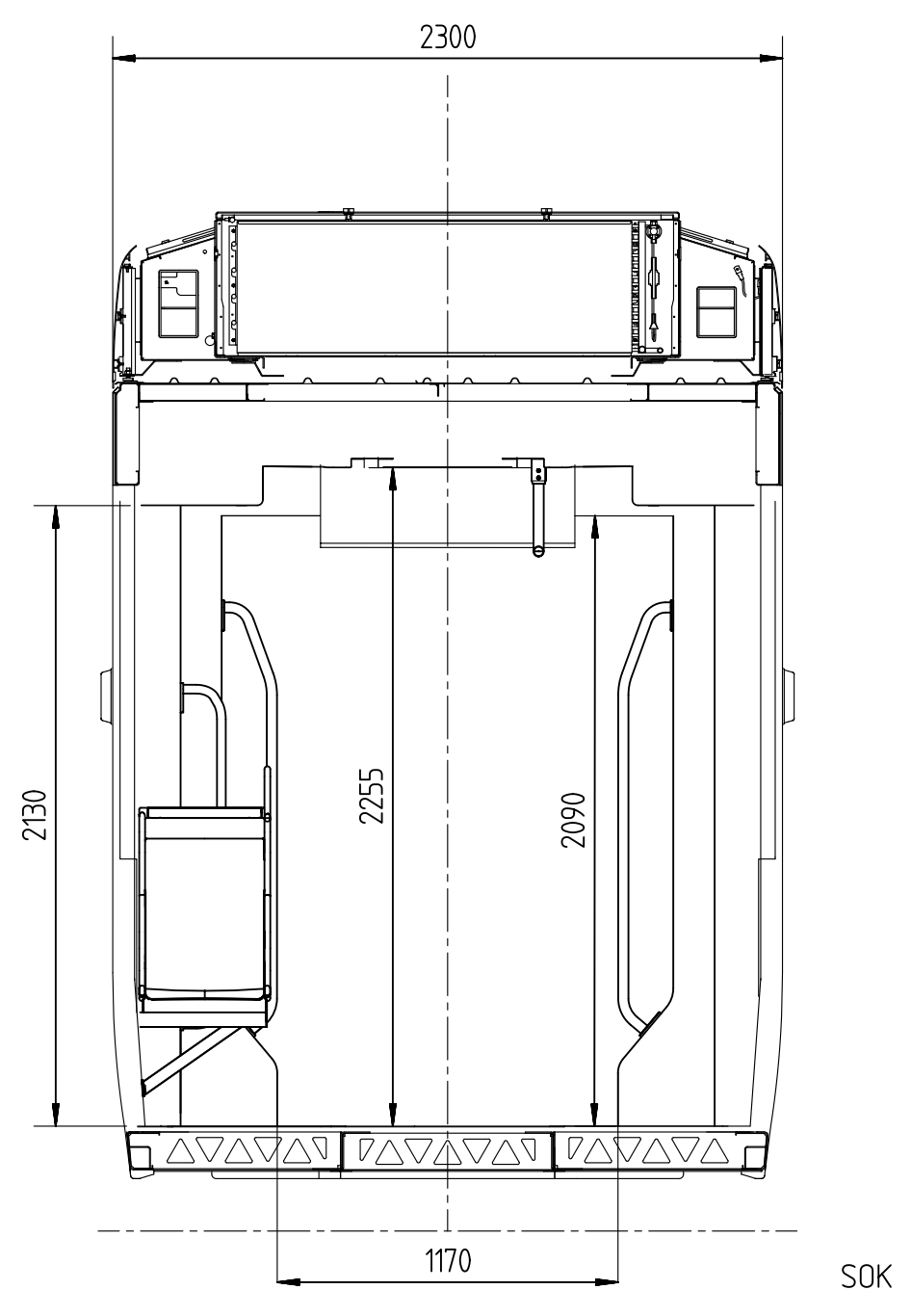

SCHNITT A

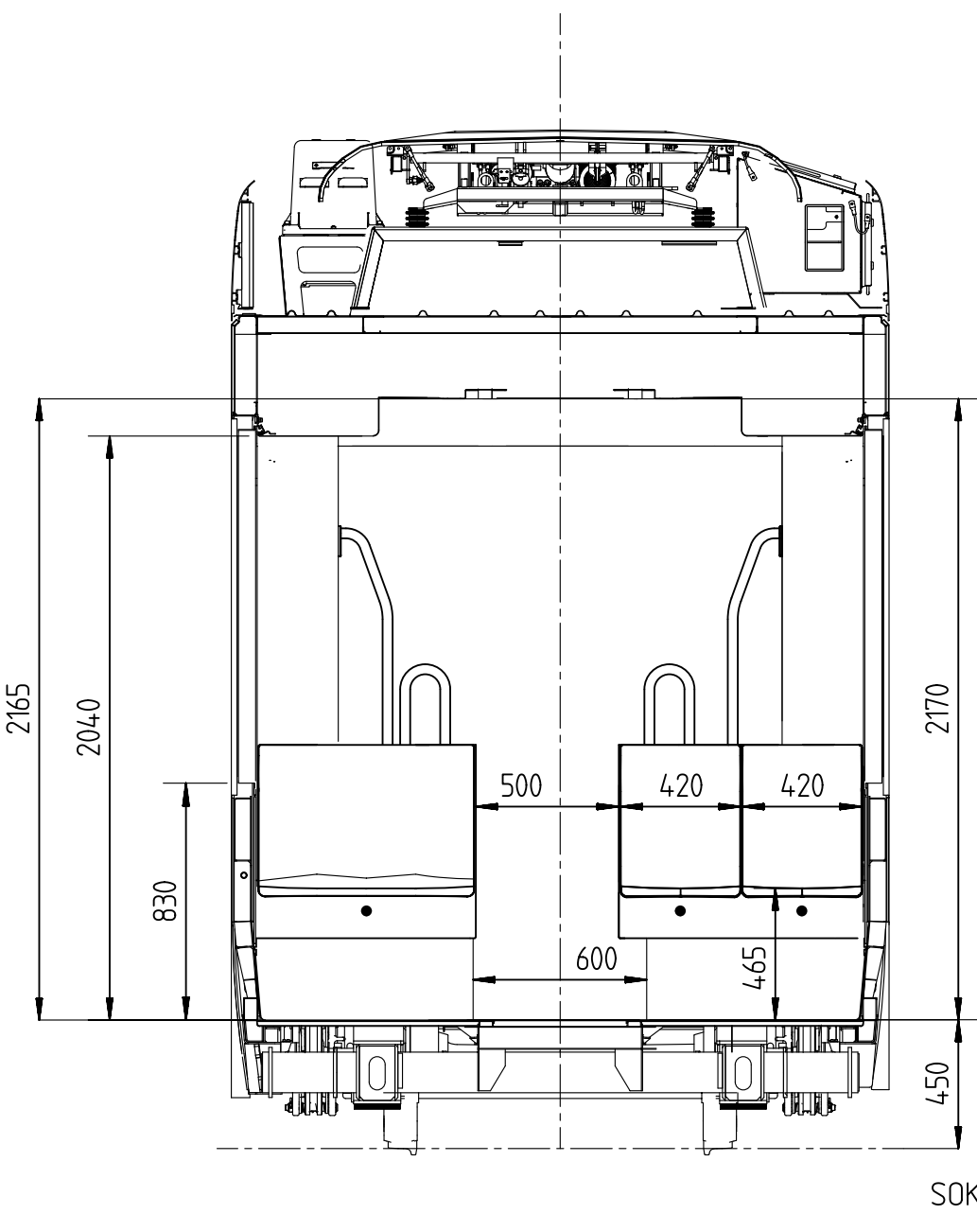

SCHNITT B

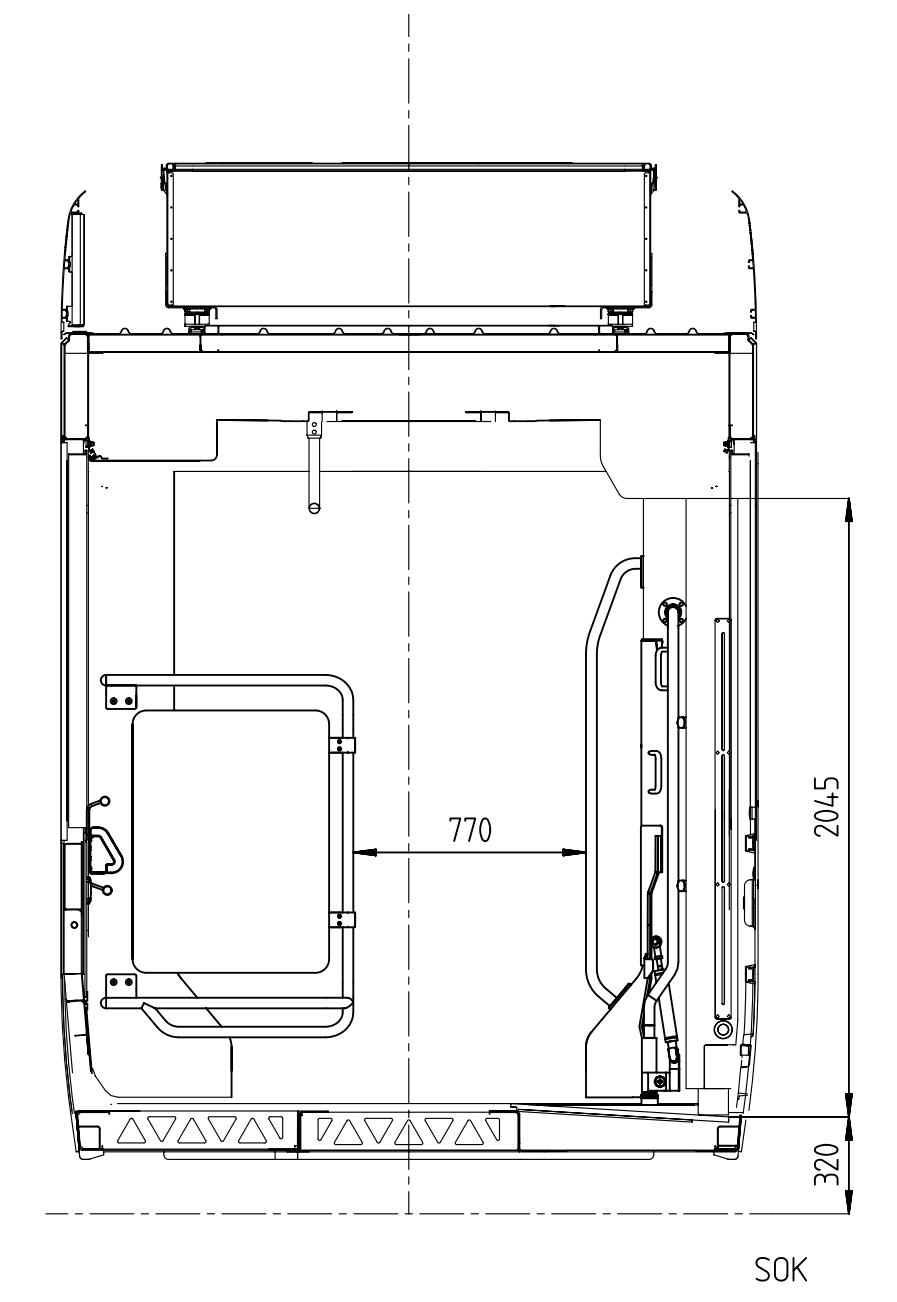

SCHNITT C

	Sitzplätze	Stehplätze	Gesamtzahl Fahrgäste
4p/m <sup>2</sup>	56	198	254
85% - 6p/m <sup>2</sup> (AB-EBV)	56	252	308
85% - 8p/m <sup>2</sup> (AB-EBV)	56	336	392

REV	ITEM	DATE	REVISOR	VERIF.	NOTES / SINGLES	NO. OF SHEETS	OF	SCALE	PROJ. NO.
01	01-01-001	20-Feb-2020	M. OETI	C. PEREZ	EN 22768 - A1 EN 12753 - B2 EN 12753 - A	1	1	1:50	BB2120000000
GENERAL LEAFLET		FABRICANT		NOMERATION		PROJECT		DRAWING	
STADLER		TRAM		BERNMOBIL		TRAMLINK BERN		E0	
BB2120000000		E0		1/2		AD			

We reserve all rights to this document and the information contained therein. No part of this document may be reproduced, stored in a retrieval system, or transmitted in any form or by any means, electronic, mechanical, photocopying, recording, or by any information storage and retrieval system, without express authority in writing from the copyright holder.